



Politechnika
Wroclawska

Fundamentals of engineering drawing

dr inż. Stanisław Frąckowiak



HR EXCELLENCE IN RESEARCH



Basics

Scope

- course definition, where to find: no idea
- contact form: stationary / on-line if necessary,
- attendance
- thematic scope of design classes,
- necessary teaching aids,
- passing, cards,
- paper folder for work, homework,
- materials: e-portal,
- consultations: stationary D-2 p. 019 at designated times or on-line via MS Teams/Consultations,
- exercise 1 + homework
- contact: stanislaw.frackowiak@pwr.edu.pl

Basics

Academic calendar- summer semester 2022/2023

	FEB	MARCH				APRIL				MAY				JUNE				JULY		
MON	27	6 Mon/O	13	20	27	3	10	17	24	1	8	15	22	29	5	12	19	26 Thu/E	3	10
TUE	28	7	14	21	28	4	11	18	25	2	9	16	23	30	6	13	20	27 Fri/E	4	11
WED	1	8	15	22	29	5	12	19	26	3	10	17	24	31	7	14	21 Mon/E	28	5	12
THU	2	9	16	23	30	6	13	20	27	4	11	18	25	1	8	15	22	29	6	13
FRI	3	10	17	24	31	7	14	21	28	5	12	19	26	2	9	16	23	30	7	14
SAT	4	11	18	25	1	8	15	22	29	6	13	20	27	3	10	17	24	1	8	15
SUN	5	12	19	26	2	9	16	23	30	7	14	21	28	4	11	18	25	2	9	16
E - EVEN O - ODD	O	E	O	E	O	E	O	E	O	E	O	E	O	E	O	E	O	E	O	E

■ Holidays
 ■ Additional days off
 ■ Changes
 ■ Session
 ■ Semester break

Attendance is obligatory, in exceptional cases 2 absences are allowed



Basics

Calendar add-on

- The summer semester begins on 28th of February 2023 and runs until 30th of September 2023.
- Organized classes start on 28th of February 2022 with an odd week and run for 15 weeks until 27th of June 2023 - 8 odd (O) weeks and 7 even (E) weeks.
 - 6 IV 2023 r. – day off from classes
 - 7 IV 2023 r. – day off from classes
 - 11 IV 2023 r. – day off from classes
 - 2 V 2023 r. – day off from classes
 - 3 V 2023 r. – 3 May Constitution Day
 - 4V 2023 r. – day off from classes
 - 5 V 2023 r. – day off from classes
 - 8 VI 2023 r. – Corpus Christi
 - 9 VI 2023 r. – day off from classes
- Easter holidays are from 6th of April 2023 to 11th of April 2023
- Examination session includes 13 working days and lasts from 28th of June 2023 to 16th of July 2023 and 3 Saturdays (1st, 8th and 15th of July 2023).
- The summer-semester break lasts from 17th of July 2023 to 30th of September 2023.



What are we going to study?

Goals

Acquainting the students with the basics of Monge's method of recording spatial geometric forms on the projection plane.

Preparation for understanding the principles of engineering drawing that is used to convey information necessary for reading simple technical drawings.

Interpretation of technical drawings and explaining the basic rules of notation of a structure.



What are we going to study?

Schedule

1. Mapping three-dimensional objects onto the plane - rectangular projection by Monge. Mapping of basic geometric elements (point, line, plane). Preparing technical drawings.
2. Extraction of geometric elements. Determination of common elements – edges and breakdown points. Transformation of the position and the reference system. Preparing technical drawings.
3. Solids - definitions. Mapping the solid on three orthogonal planes. Dragging, projection, construction plane. Preparing technical drawings.
4. Fundamentals of polyhedra shapes. Sections of polyhedra with projecting planes and cutting planes. Preparing technical drawings.
5. Fundamentals of revolving solids (cone, cylinder, sphere). Sections of revolving solids with projecting planes and cutting planes. Preparing technical drawings.
6. Penetration of surfaces, drawing of surface development. Cylindrical surfaces. The interpenetration of penetration curve of a cylinder. Preparing technical drawings.
7. Colloquium K1 (includes exercise material of 1 - 6).



What are we going to study?

Schedule

8. Engineering drawing - section view fundamentals (partial views, half-views), types of sections (full sections, half sections, broken out sections). Preparing technical drawings.
9. Completing the missing solid's projection - use of the axonometric projection. Preparing technical drawings.
10. Drawing standardized machine connections. Design of welded connections. Preparing technical drawings.
11. Drawing standardized machine connections. Threaded connections. Preparing technical drawings.
12. Dimensions and tolerances of mating machined parts. Preparing technical drawings.
13. Assembly drawing and drawings of components (drawing rules). Preparing technical drawings.
14. Colloquium K2 (includes exercise material of 8 - 13).
15. Correction exercise. Passing.



What are we going to study?

Literature

- Bogaczyk T., Romaszekiewicz-Białas T.: **13 wykładów z geometrii wykreślnej**
- Bogaczyk T., Romaszekiewicz-Białas T.: Grafika inżynierska. Teoria. Wrocław 2014
- Dobrzański T.: Rysunek techniczny maszynowy. WNT, Warszawa 2021
- Miśniakiewicz E., Skowroński W.: Rysunek techniczny budowlany. Arkady, Warszawa 2013
- Popek M., Wapińska B.: Rysunek zawodowy. Instalacje sanitarne, WSiP, Warszawa 2010
- Januszewski B.: Rysunek techniczny w projektowaniu instalacji sanitarnych, Oficyna Wydawnicza Politechniki Rzeszowskiej, Rzeszów 1999
- Żurek M.: Projektowanie instalacji budowlanych, Instytut Technologii Eksploatacji Państwowy Instytut Badawczy, Radom 2005



What are we going to study?

Other literature

- Dyba K.: Geometria rzutów. Oficyna Wydawnicza Politechniki Wrocławskiej, 1982
- Samujłło H. i J.: Rysunek techniczny i odręczny w budownictwie. Arkady, Warszawa 2000
- Wasilewski Z.: Rysunek zawodowy Instalacje sanitarne i rurociągi przemysłowe, WSiP, Warszawa 1993



What are we going to study?

- ruler, set squares,
- compass,
- pencils of various thicknesses, sharpener,
- non-smear eraser,
- A4 technical block,
- sheets of A3 technical block,
- plasticine/modeling clay, polystyrene,
- technical writing practice paper,
- white briefcase tied/with an elastic band



Project

Passing the course - requirements

- independent performance of all drawing exercises,
- delivering work on time; works are handed from time to time (approximately every two classes) and after completion should be kept in the personal folder, in the case of switching to remote mode, the works will have to be scanned and placed on the e-portal within the specified period,
- obtaining credit for **all** works,
- attendance,
- writing both tests and passing them,
- defense of selected works,
- work in class.



Project

Evaluation criteria:

- works are evaluated in terms of substantive correctness and aesthetics of performance
- work delivered on time - "starting" grade: 5.0
- work submitted after the deadline - "starting" grade: 1 week late - 4.0
- 2 weeks delay - 3.0
- works directed to improvement and delivered on time - "starting" grade: 4.0
- final grade from design exercises:
- (arithmetic mean of the grades obtained from the assignments + arithmetic mean of the quizzes)/2
- the instructor has the option to change the final grade by +/- 0.5 grade at his discretion



Project

Quizzes

- from selected topics;
- at the beginning of classes,
- work must be independent,
- in case if someone fails, it is possible to improve, during classes or consultations,



Project

Folder and the title box

Politechnika Wroclawska
 Wydział wysokość opisu ok. 10mm
 Inżynierii Środowiska

RYSUNEK TECHNICZNY

Nr zajęć	1	2	3	4	5	6	7	15
Praca na zajęciach								15
Praca w domu								25
Nr zajęć	8	9	10	11	12	13	14	
Praca na zajęciach								
Praca w domu								
40	7x20=140							

Imię i Nazwisko
Grupa (np. pon. 11.15-12.45)
Rok akad. 2012/2013

180					
30		20		50	
				15	15
50	50	50	50	50	50
Podziałka		Imię i Nazwisko		Data	Podpis
1:1		Kreślił Jan KOWALSKI		11.12.99	
		Sprawdził Jan MATEJKO		15.12.99	
Nazwa rysunku				Nr rysunku	
Nazwa pracy rysunkowej				1/1	

Project

Basic format and frame

- Sheet formats for technical drawings are standardized (PN-80/N-01612)
- A sheet of 297 x 210 mm was adopted as the basic format and was marked with the symbol A4
- The basic formats are multiples of the basic A4 format and marked with the symbols A3, A2, A1, A0
- Each technical drawing, regardless of its format, must be framed
- The frame should be made with a continuous line at a distance of $a=5\text{mm}$ from the edge of the sheet on A3 and smaller formats and $a=7-10\text{mm}$ on larger formats. Border line thickness min. 0.7mm

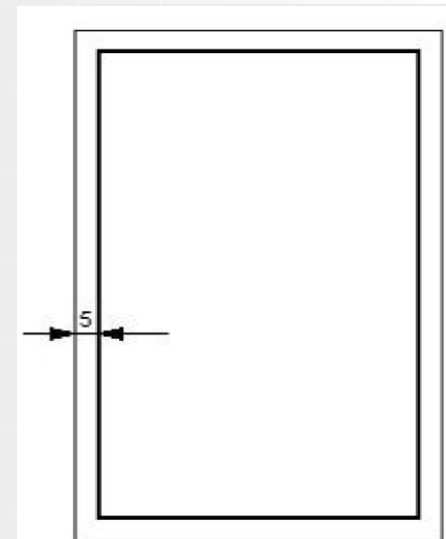
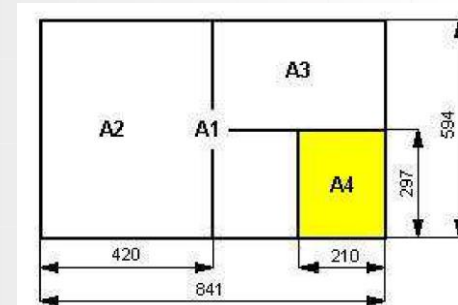

Project

Basic geometrical elements of Euclidean space and description

- points – capital letters of the Latin alphabet (A, B, C...)
- lines – lowercase Latin letters (a, b, c...)
- planes – small letters of the Greek alphabet (α , β , γ ...)
- the binding direction of writing is always horizontal.

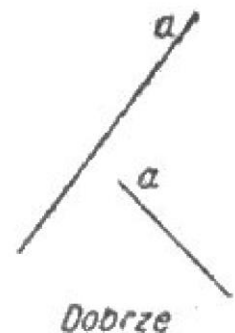
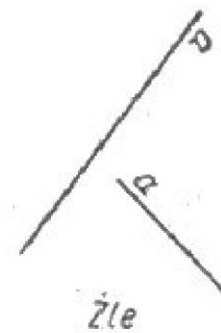
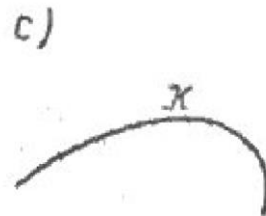
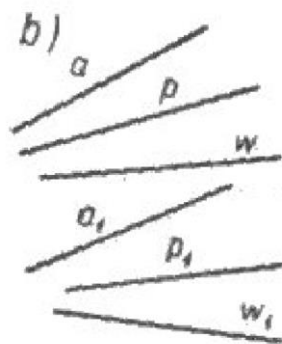
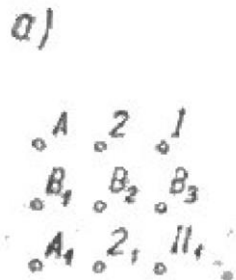



Project

Elements of the drawing

- elements whose type, location, etc. is specified in the subject of the task are **given elements**
- elements not given in the topic, but those whose placement in the drawing is necessary to obtain a solution, are **auxiliary elements**
- the searched elements that constitute the solution to the task are the **result elements**
- individual elements are distinguished in the drawings by their appropriate plotting,
- points: given and auxiliary point - identical - circle with a diameter of approx. 1-2 mm
- for the line is marked as follows:
 - the comparative thickness is the thickness of the data line - typically 0.5 mm.
 - the result lines are about 2 times thicker than the data lines, and the auxiliary lines are 2 times thinner.

Project

Types of mappings on a plane - types of projections

All types of mapping representing on the drawing plane spatial (3D) objects use the projection method

The most popular are:

- parallel projection (axonometry) - illustrative and measuring drawing,
- parallel orthogonal projection (according to Monge's method) - measuring drawing,
- middle view (perspective) - mainly illustrative.

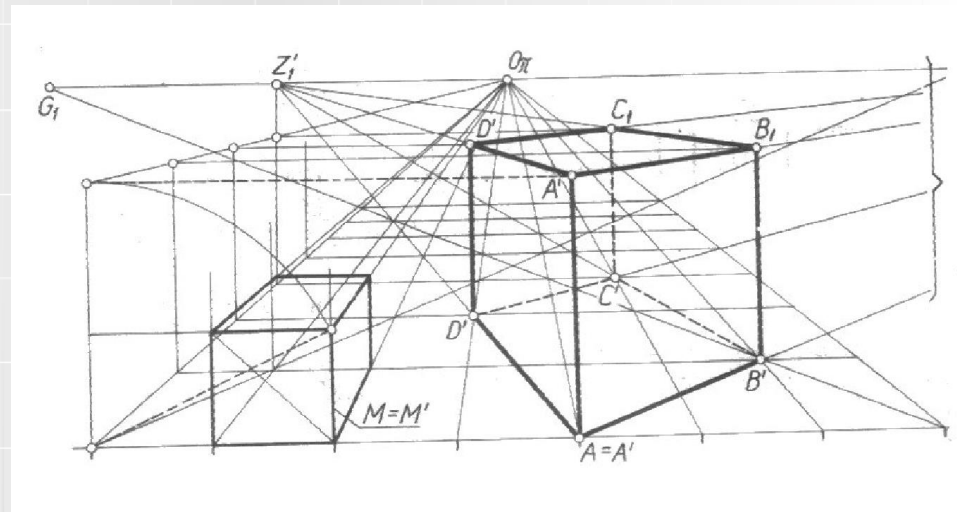
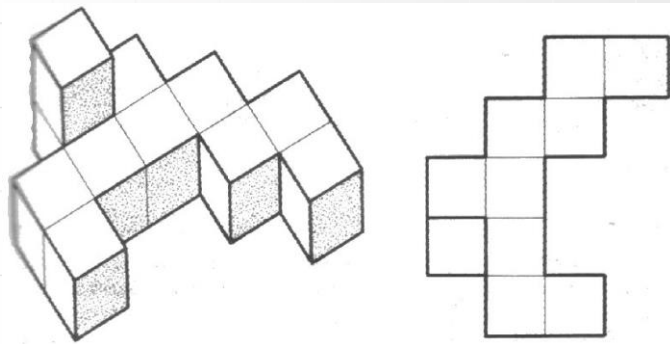

Project

Parallel projection (axonometry)

There are two basic types of axonometry:

- **dimetry**,
- **isometry** (military perspective) - length of units constant

Construction:

On the drawing plane, we take two semi-axes x and z as

perpendicular to each other and the semi-axis y at an angle of 45° to the x -axis.

On the x and z axes, we set aside a unit segment, and on the y axis, it is half as long.

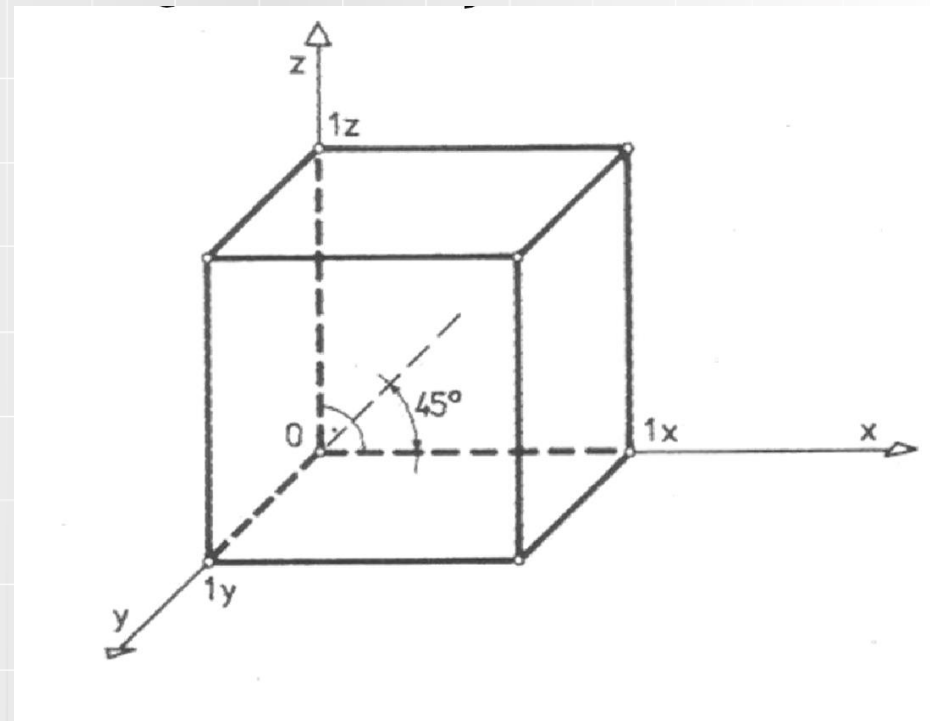

Project

Parallel projection (axonometry) - examples

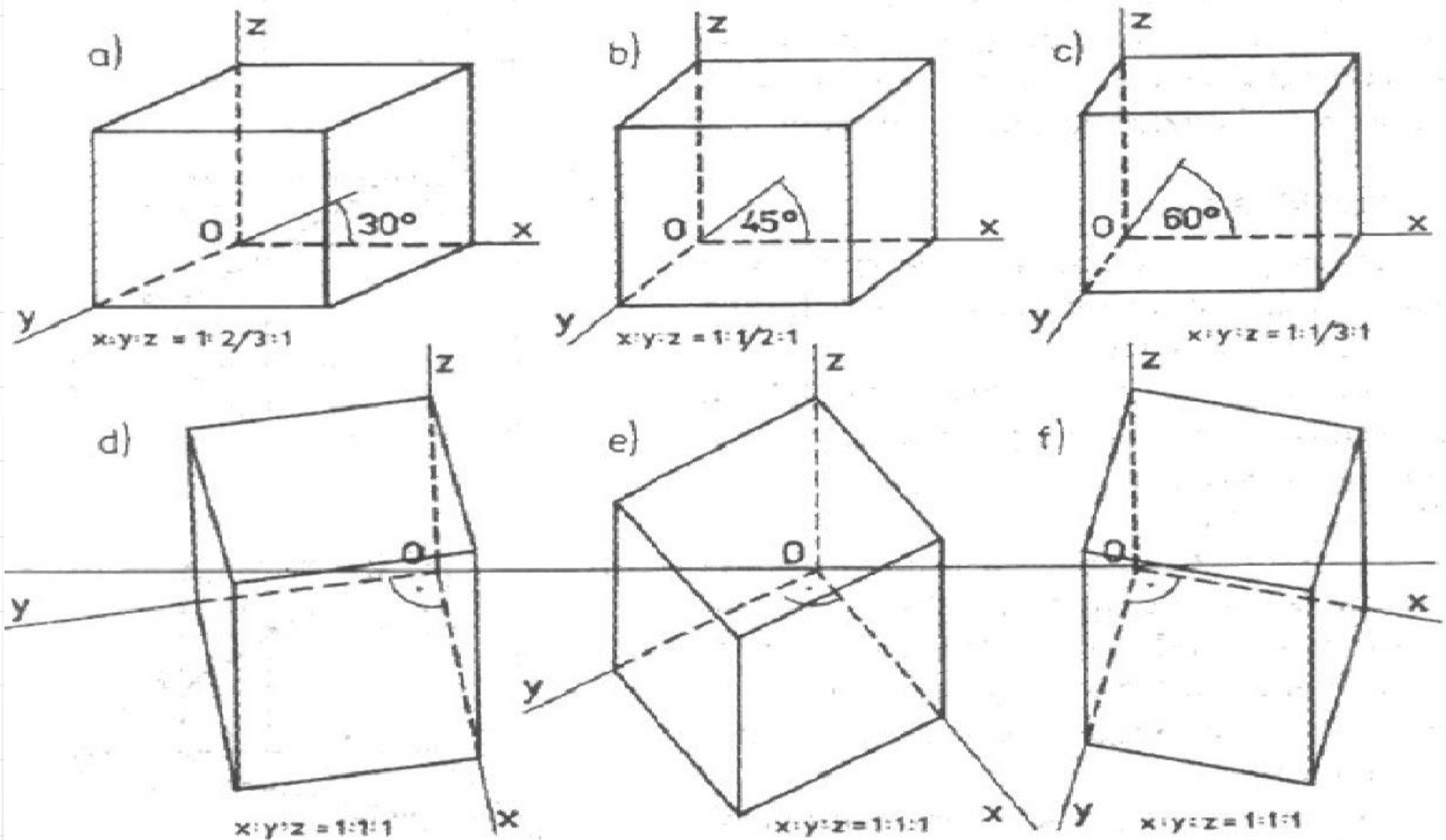

Project

Parallel projection – example 1

- Points A, B, C belong to the cutting plane; first we look for a common pair of points lying on the same plane (face of the cube)
- The line k_1 intersects the projection axes x and z at points X and Z as intersections:
 - X – base γ and back wall β
 - Z – left side wall δ and rear wall β

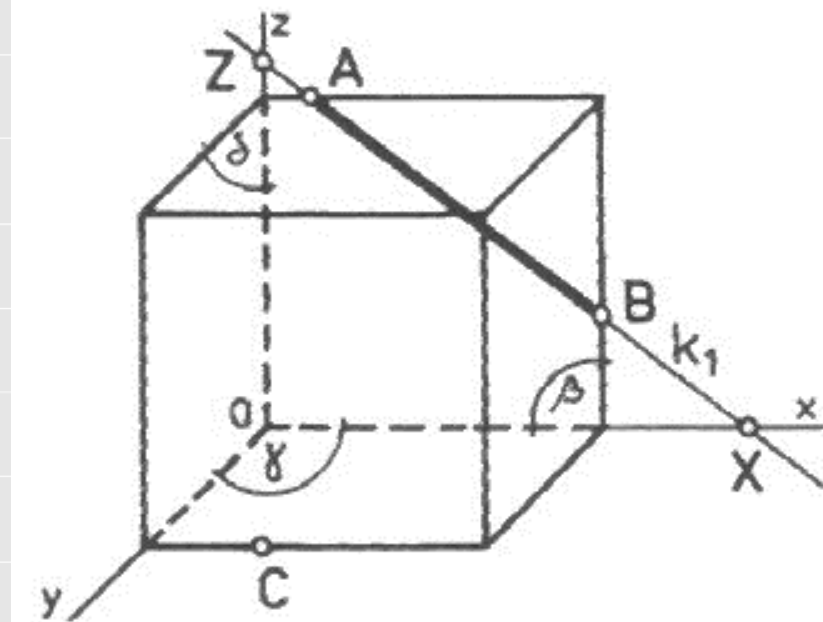
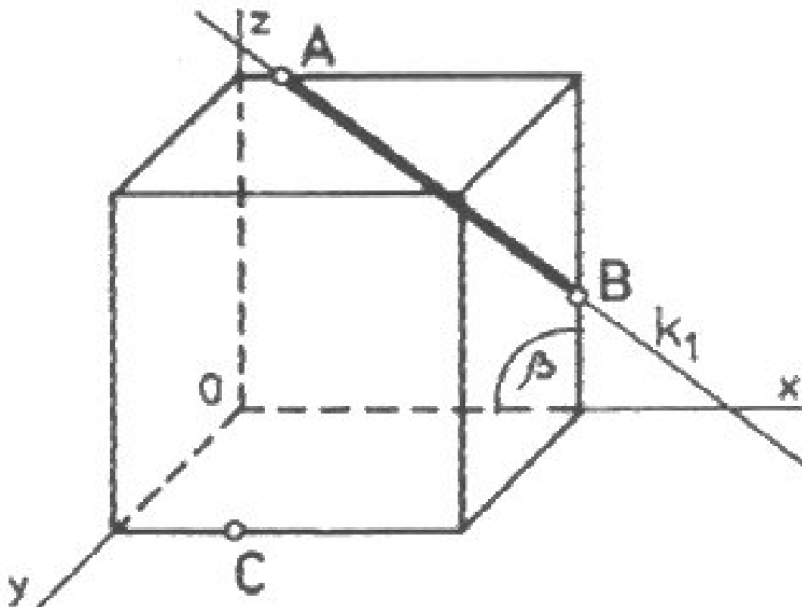

Project

Parallel projection – example 1

The line k_1 is defined by points A and B belonging to α , so points X and Z also belong to this plane.

the pair of C and X defines the line k_2 as the intersection of α and γ .

point D and B lie on the same face of the cube - the segment DB is the next edge of the section k_3 ,

NOTE: when a set of parallel planes $\alpha_1, \alpha_2, \alpha_3, \dots$ is intersected by a plane ϵ not belonging to the set $\alpha_i, i = 1, 2, 3, \dots$, the edges of intersections form a family of parallel lines $k_i, i = 1, 2, 3, \dots$

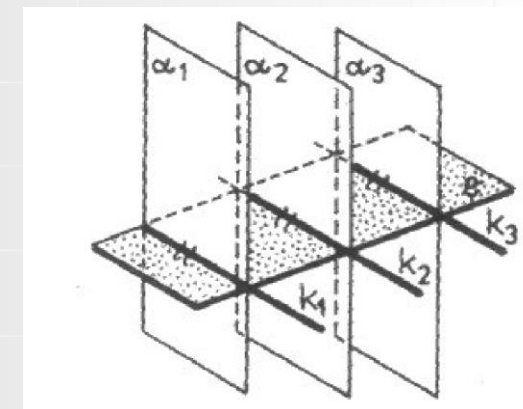
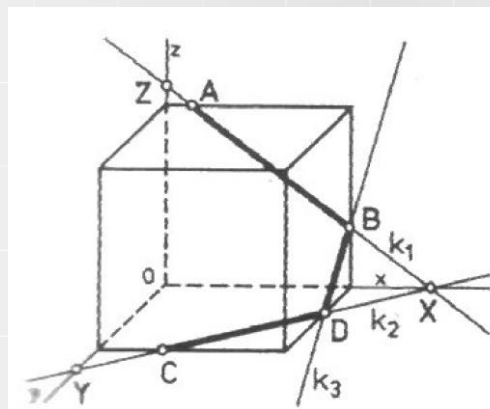
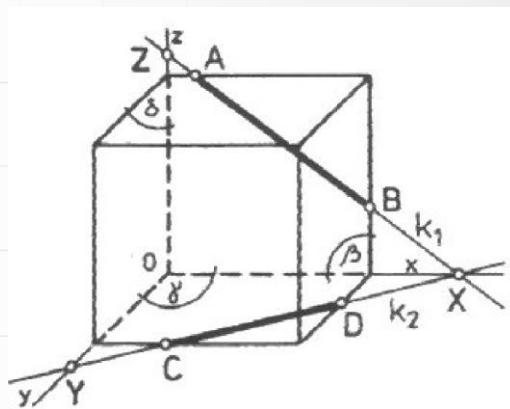

Project

Parallel projection – example 1

- by virtue of the theorem in parallel projection, the image of parallel lines in space are parallel lines as their projection - this determines the successive edges of the section k_4, k_5, k_6 .

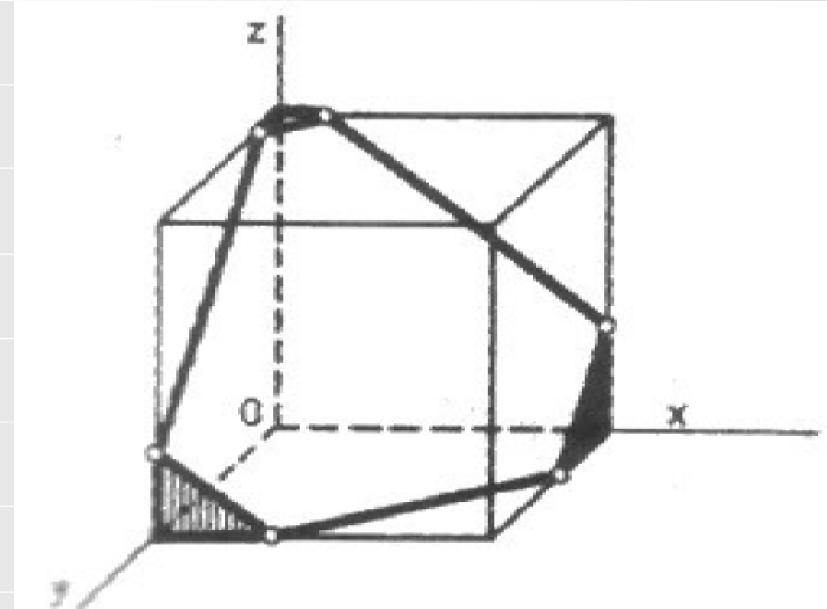
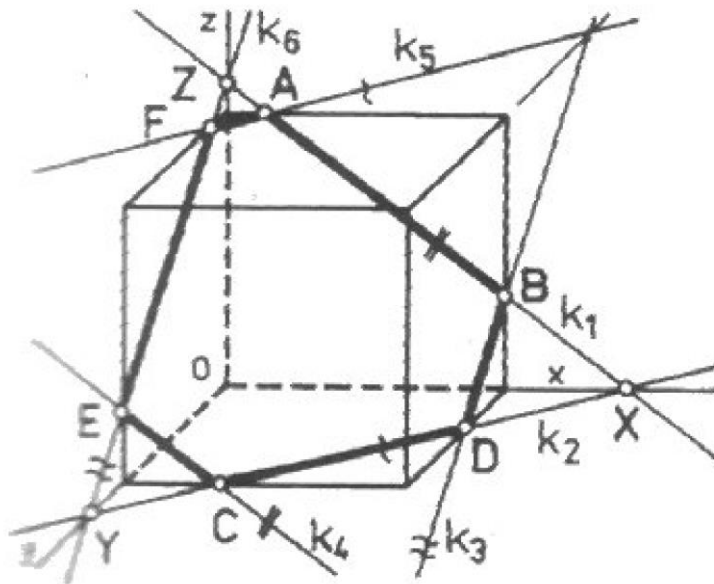

Project

Parallel projection – example 2

- Given is a polyhedron inscribed in a cube in parallel axonometry. The points A, B, C define the cutting plane α .
- Construct a cross-section of the polyhedron, leaving part of it below the cutting plane.
- The pair of points A and B lie on the same face of the polyhedron and define the edge of section k_1 .

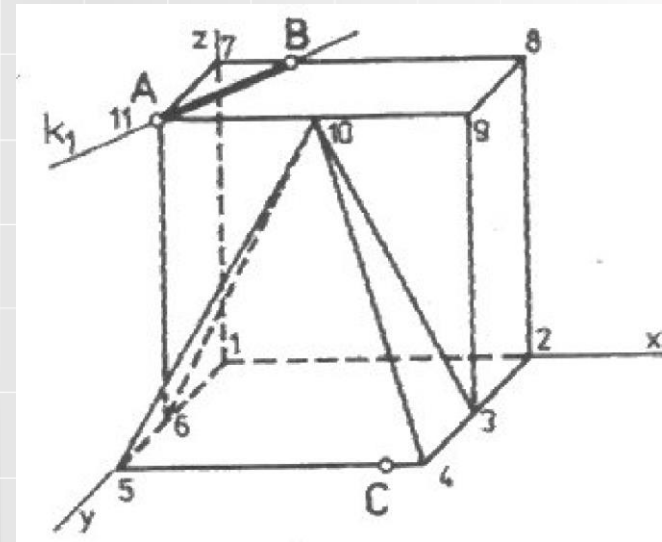
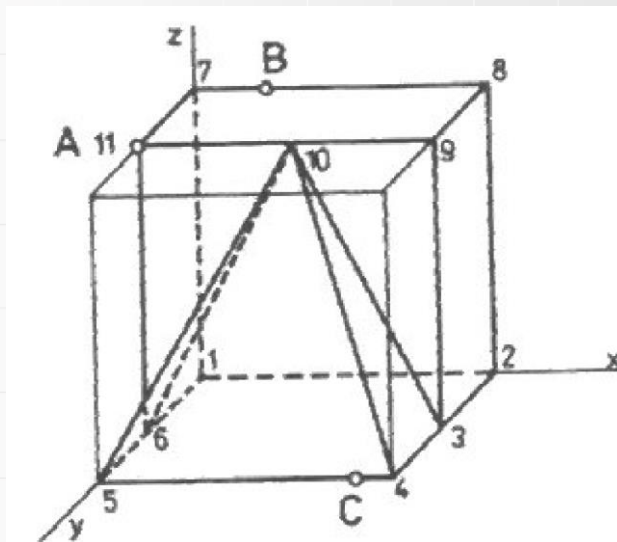

Project

Parallel projection – example 2

- The edge (1,2) of the polyhedron is the common part of the base and the back face.
- Line k_2 intersects line (1, 2) - axis x at point E .
- Since E and B belong to the rear wall, they define the edge of section BF (k_3)
- Points D and F belong to the right side face of the cube, so the line k_4 intersects the edge (9,3) of the polyhedron at point G

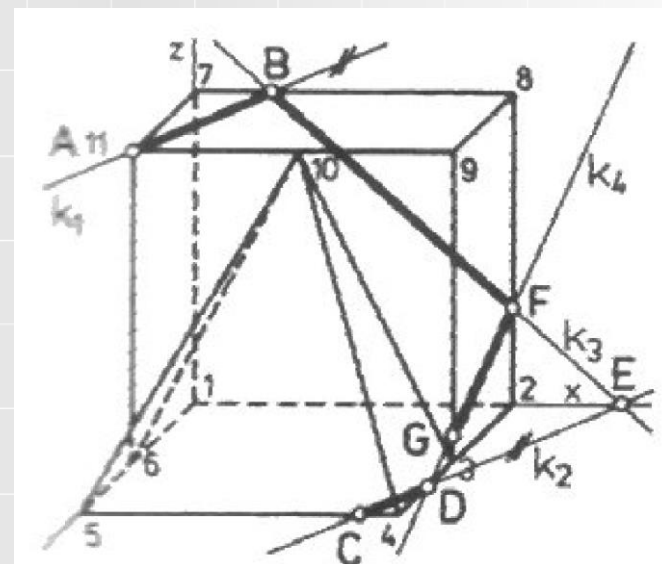
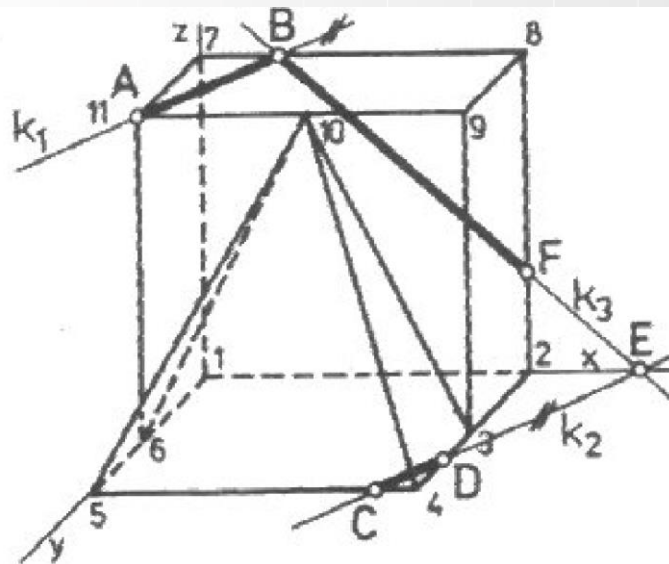

Project

Parallel projection – example 2

- Points A and G belong to the same face of the polyhedron (11, 9, 3, 6) and determine the edges of the section AH and IG lying on the line k_5 (where $k_5 \parallel k_3$)
- The triangle of the front face of the polyhedron (4,5,10) defines a plane that intersects the top face of the polyhedron (7,8,9,11) in a straight line determined by points 11 and 9, points A and C therefore lie on the same face of the polyhedron (4, 5,10), determining the common straight line k_6 and the edge of the section CJ.

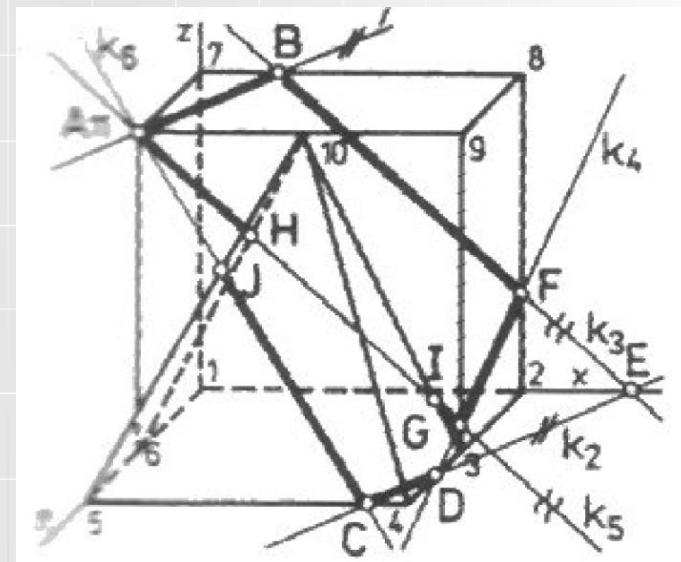
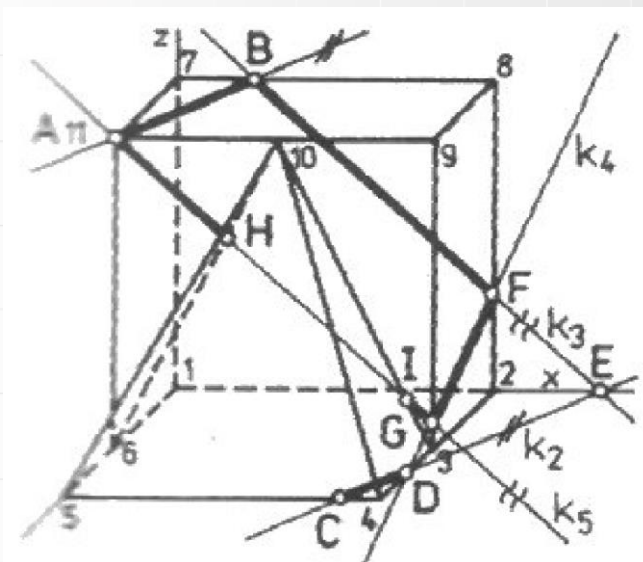

Project

Parallel projection – example 3

- Given is a polyhedron inscribed in a cube in parallel axonometry.
- The points A, B, C define the cutting plane α .
- Construct a cross-section of the polyhedron, leaving part of it below the cutting plane.

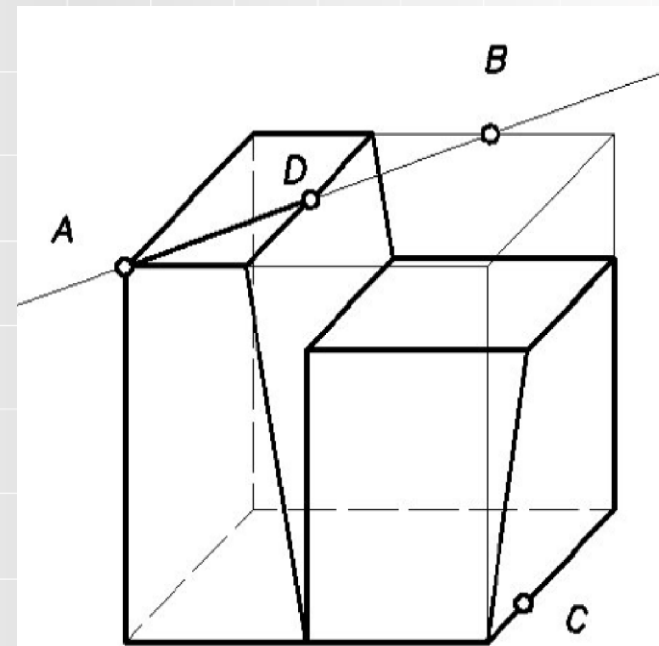
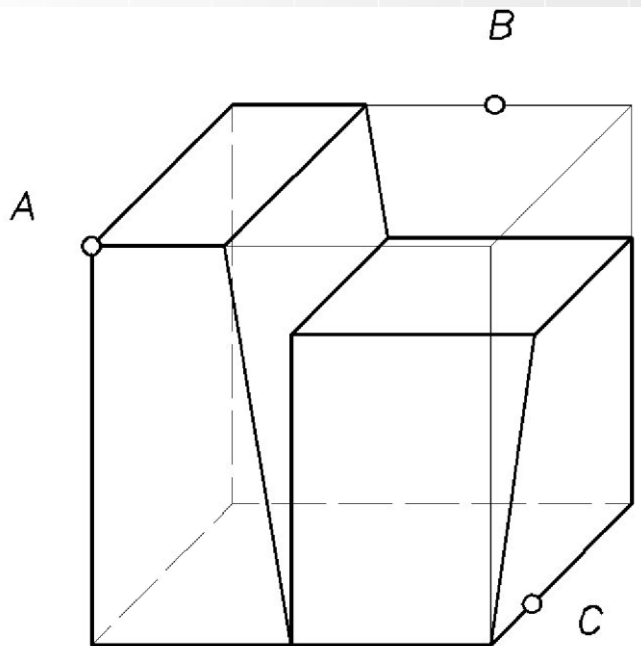

Project

Parallel projection – example 3

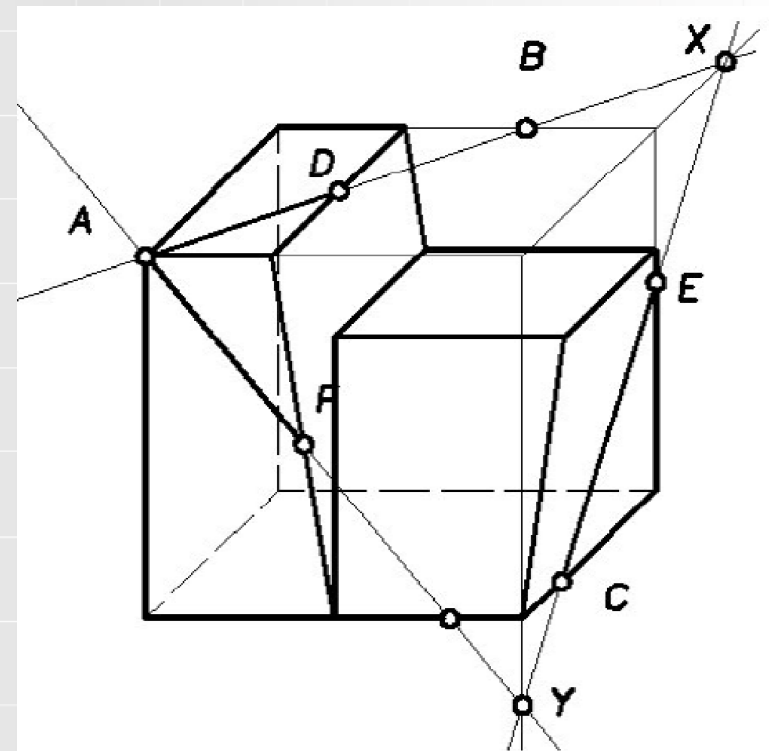
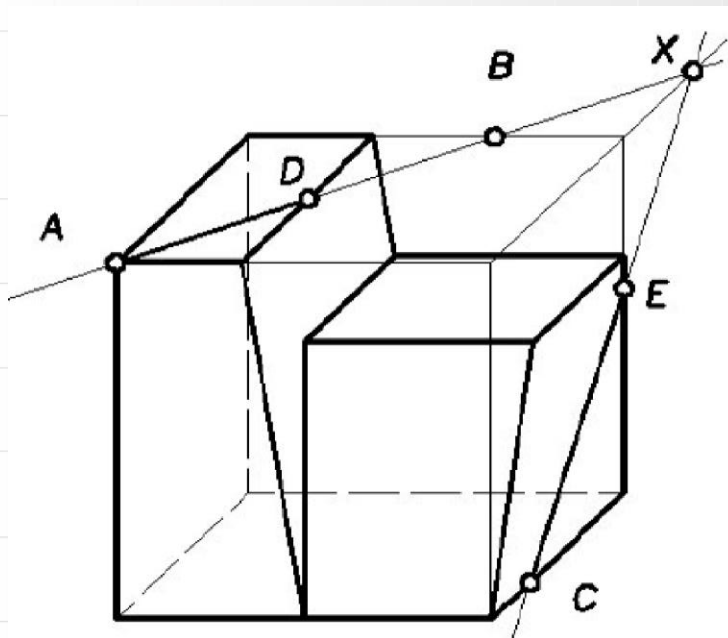

Project

Parallel projection – example 3

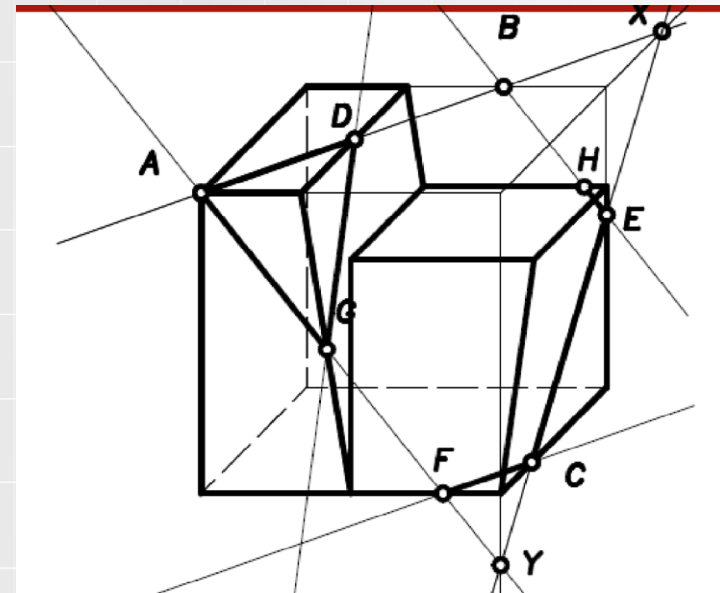
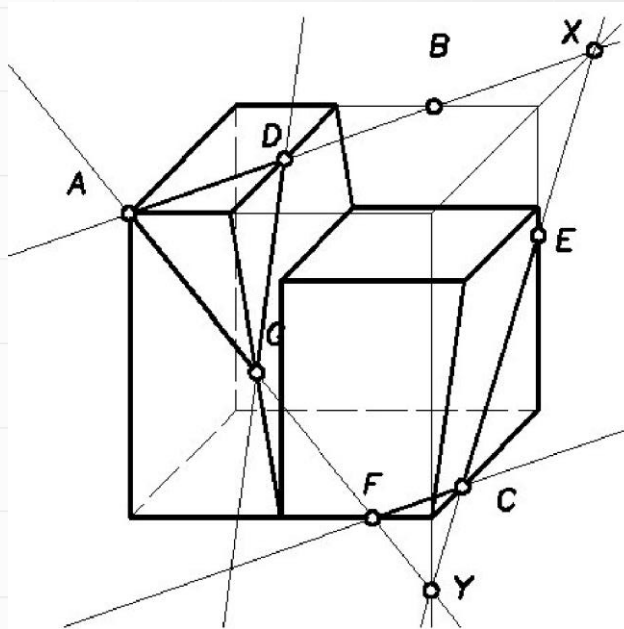

Project

Parallel projection – example 3

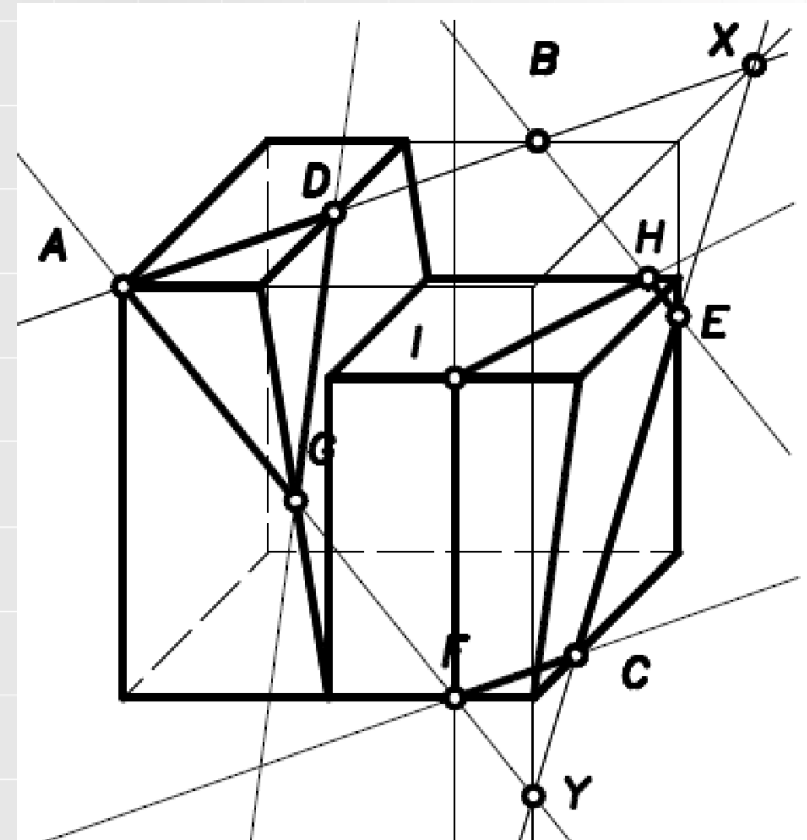
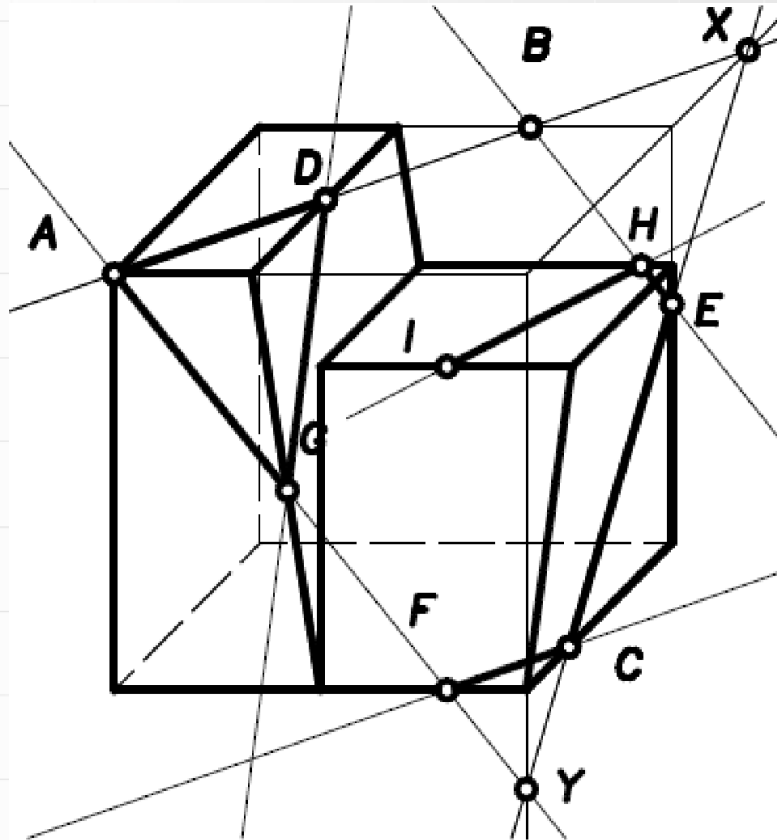

Project

Parallel projection – example 3

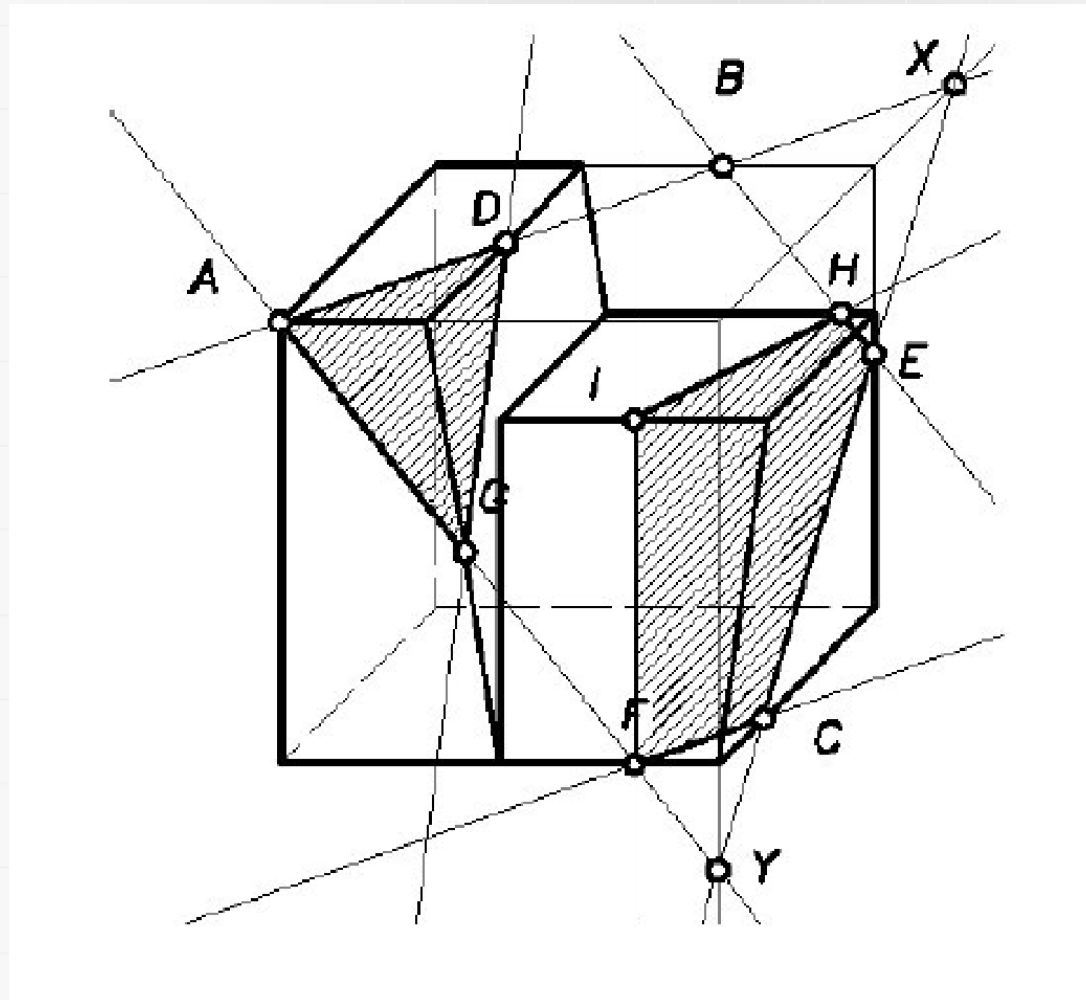

Project no 1

Homework 1/1

— 32 —

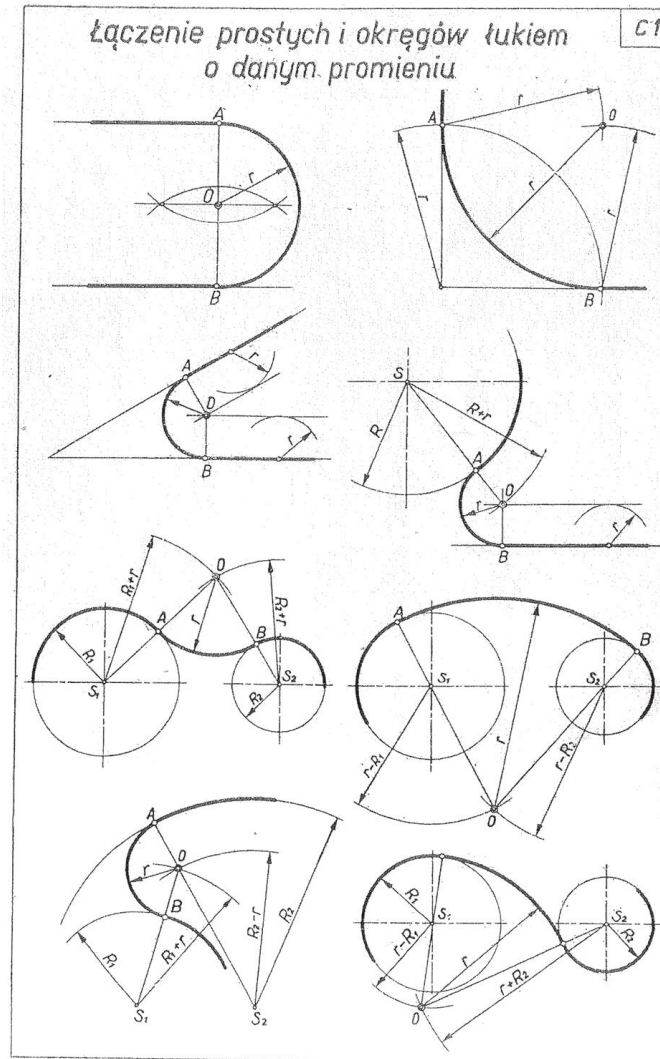

Project no 1

Homework 1/2

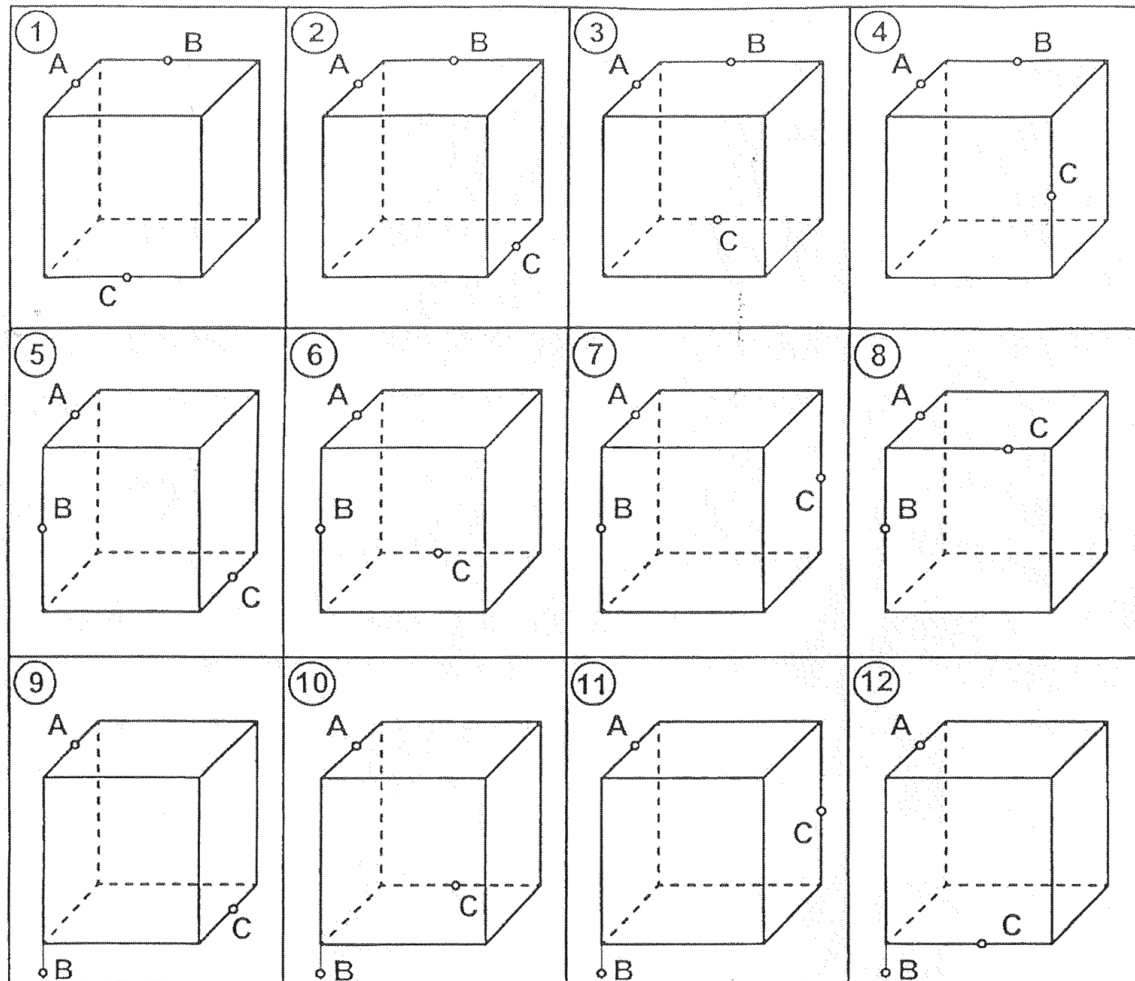

PROJEKT nr 1

Homework 1/3

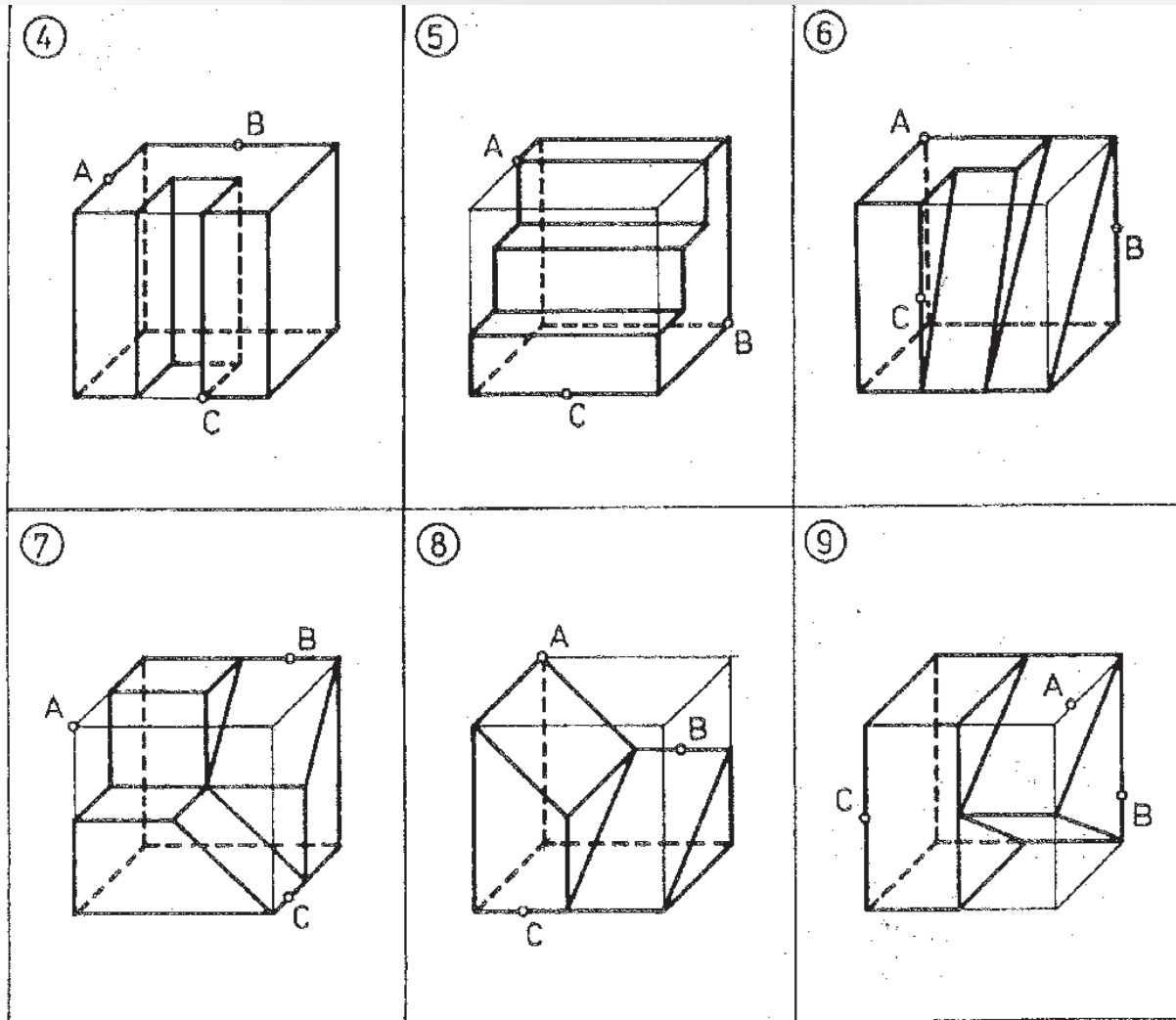



Questions ?

If so:

stanislaw.frackowiak@pwr.edu.pl